

**Ersatzteilliste**  
**Spare Parts List**  
**Liste de pièces détachées**  
**Lista de piezas de repuesto**

8/98

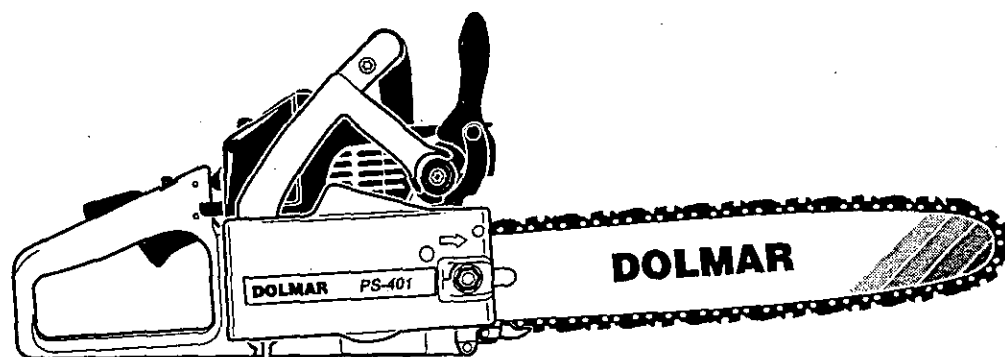

**PS-33** 43600 →  
**PS-330** D: ab Herbst '98

**PS-340**  
**PS-341**  
**PS-342**  
**PS-344**

**PS-400**  
**PS-401**  
**PS-410**  
**PS-411**

---

**DOLMAR**

995 700 079 (D, GB, F, E)





PS-33 PS-340 PS-400  
 PS-330 PS-341 PS-401  
 PS-342 PS-410  
 PS-344 PS-411

2

Zylinder, Kurbelgehäuse  
 Cylinder, crankcase  
 Cylindre, carter-vilebrequin  
 Cilíndro, cárter cigüeñal

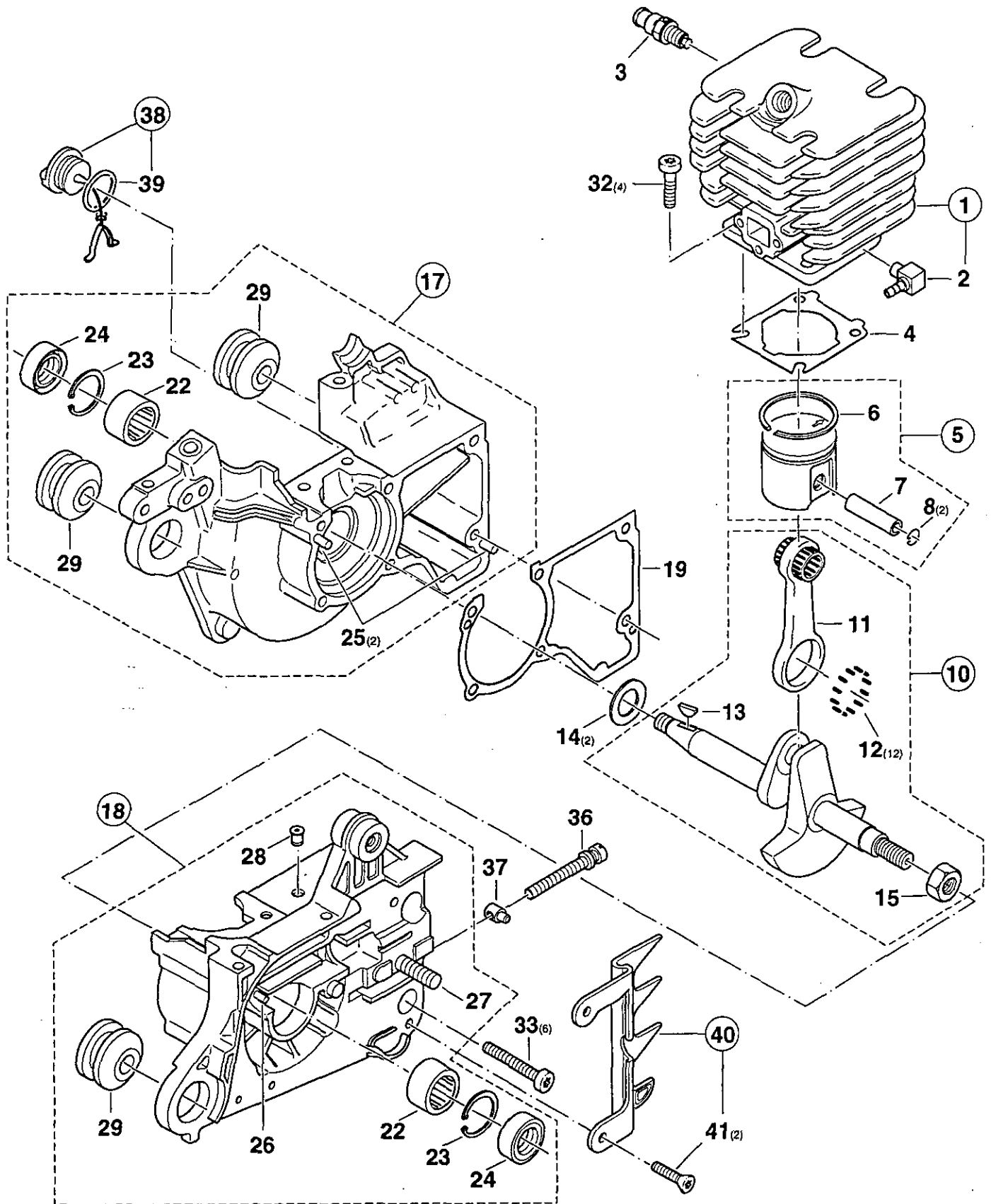
**DOLMAR**



PS-33/330 PS-340 PS-341 PS-342 PS-344 PS-400 PS-401 PS-410 PS-411										2		Zylinder, Kurbelgehäuse Cylinder, crankcase Cylindre, carter-vilebrequin Cilindro, cárter cigüeñal			<b>DOLMAR</b> 	
Pos.	Anz. Qty. Qté. Cdad.										Teil-Nr. Part No. No. de pieza	Hinweise Notes Renseig. Nota	Benennung	Description	Désignation	Denominación
1	1	1									021 131 110		Zylinder ø 37	Cylinder	Cylindre	Cilindro
1		1	1								021 131 160		Zylinder ø 37	Cylinder	Cylindre	Cilindro
1				1				1			028 131 230		Zylinder ø 40	Cylinder	Cylindre	Cilindro
1					1				1		028 131 160		Zylinder ø 40	Cylinder	Cylindre	Cilindro
2	1	1	1	1	1	1	1	1	1		001 151 670		Winkelrippel	Angular nipple	Téton coudé	Boquilla de tubo
3		1	1	1	1	1	1	1	1		001 131 150		Dekompressionsventil	Decompression valve	Soupape de décompress.	Válvula de décompress.
4	1	1	1	1	1	1	1	1	1		965 524 042		Dichtung	Gasket	Joint	Junta
5	1	1	1	1	1						021 132 110		Kolben kpl. ø 37	Piston assy.	Piston cpl.	Pistón cpl.
5					1	1			1		028 132 110		Kolben kpl. ø 40	Piston assy.	Piston cpl.	Pistón cpl.
6	1	1	1	1	1						021 132 030		Kolbenring ø 37	Piston ring	Segment de piston	Segment de pistón
6					1	1			1		021 132 230		Kolbenring ø 40	Piston ring	Segment de piston	Segment de pistón
7	1	1	1	1	1	1	1	1	1		021 132 020		Kolbenbolzen	Piston pin	Axe de piston	Perno de pistón
8	2	2	2	2	2	2	2	2	2		108 132 050		Sprengring	Spring ring	Anneau ressort	Anillo elástico
10	1	1	1	1	1	1	1	1	1		957 120 028	SI 12/95	Kurbelwelle kpl.	Crankshaft cpl.	Vilebrequin cpl.	Cigüeñal cpl.
11	1	1	1	1	1	1	1	1	1		021 123 010		Pleuel kpl.	Con-rod cpl.	Bielle cpl.	Biela cpl.
12										12	962 640 061		Rolle	Roller	Rouleau	Rodillo
13	1	1	1	1	1	1	1	1	1		939 615 260		Scheibenfeder	Key	Clavette	Chaveta
14	2	2	2	2	2	2	2	2	2		108 121 010		Anlaufscheibe	Stop disc	Disque portant	Disco de tope
15	1	1	1	1	1	1	1	1	1		920 108 044	SI 12/95	6kt-Mutter M8x1 L	Hexagonal nut, left thr.	Ecrou hex., gauche	Tuerca hexagonal, izqu.
17	1	1	1	1	1	1	1	1	1		028 111 040		Kurbelgehäuse MS kpl.	Crankcase, m. side cpl.	Carter-côte mag. cpl.	Cárter cig. lado magn. cpl.
18	1	1	1	1	1	1	1	1	1		028 111 030		Kurbelgehäuse KS kpl.	Crankcase, cl. side cpl.	Carter-côte embr. cpl.	Cárter cig. lado embr. cpl.
19	1	1	1	1	1	1	1	1	1		965 524 010		Dichtung =>	Gasket	Joint	Junta
19	1	1	1	1	1	1	1	1	1		965 524 011		Dichtung <=<	Gasket	Joint	Junta
22	2	2	2	2	2	2	2	2	2		962 300 011		Nadelhülse	Needle bush	Roulement à aiguilles	Jaula de agujas
23	2	2	2	2	2	2	2	2	2		929 319 101		Sicherungsring	Snap ring	Circlip	Anillo
24	2	2	2	2	2	2	2	2	2		962 900 047		Radialdichtring =>	Radial ring	Joint radial	Anillo radia
24	2	2	2	2	2	2	2	2	2		962 900 049		Radialdichtring <=<	Radial ring	Joint radial	Anillo radia
25	2	2	2	2	2	2	2	2	2		936 430 160		Spiralspannstift	Spiral pin	Goupille	Pasador
26	1	1	1	1	1	1	1	1	1		021 245 070		Führungsstift	Guide pin	Goupille de guidage	Prisionero
27	1	1	1	1	1	1	1	1	1		905 808 254		Stiftschraube M8x25	Bolt	Boulon	Bulón
28	1	1	1	1	1	1	1	1	1		010 245 010		Belüftungsventil. Öl	Vent valve, oil	Soupape d' aération, huile	Válvula ventilación, aceite
29	3	3	3	3	3	3	3	3	3		965 403 490		Schwingungsdämpfer	Rubber buffer	Amortisseur	Amortiguador
32	4	4	4	4	4	4	4	4	4		908 405 255		Schraube ø M5x25	Screw	Vis	Tornillo
33	6	6	6	6	6	6	6	6	6		908 005 305		Schraube ø M5x30	Screw	Vis	Tornillo
36	1	1	1	1	1	1	1	1	1		389 213 080		Spannschraube	Straining screw	Vis de tension	Tornillo
37	1	1	1	1	1	1	1	1	1		001 213 041		Vierkantmutter m. Zapfen =>	Square nut with pivot	Ecrou carré avec pivot	Tuerca cuadr. con perno
37	1	1	1	1	1	1	1	1	1		001 213 042		Vierkantmutter m. Zapfen <=<	Square nut with pivot	Ecrou carré avec pivot	Tuerca cuadr. con perno
38	1	1	1	1	1	1	1	1	1		965 450 040		Öltankverschluß kpl.	Oil tank plug assy.	Bouchon res. d' huile cpl.	Cierre depósito aceite
39	1	1	1	1	1	1	1	1	1		963 100 041		Dichtung	Gasket	Joint	Junta
40	=	1	1	1	1	1	1	1	1		957 250 015		Zackenleiste kpl.	Spike bar assy.	Barre dentée cpl.	Barra dentada cpl.
41	=	2	2	2	2	2	2	2	2		908 105 124		Schraube ø M5x12	Screw	Vis	Tornillo

PS-33 PS-340 PS-400  
PS-330 PS-341 PS-401  
PS-342 PS-410  
PS-344 PS-411

3

Zündelektronik, Anwerfvorrichtung  
ignition electronics, starter  
Allumage électronique, dispositif de démarrage  
Bobina encendido, dispositivo de arranque

**DOLMAR**

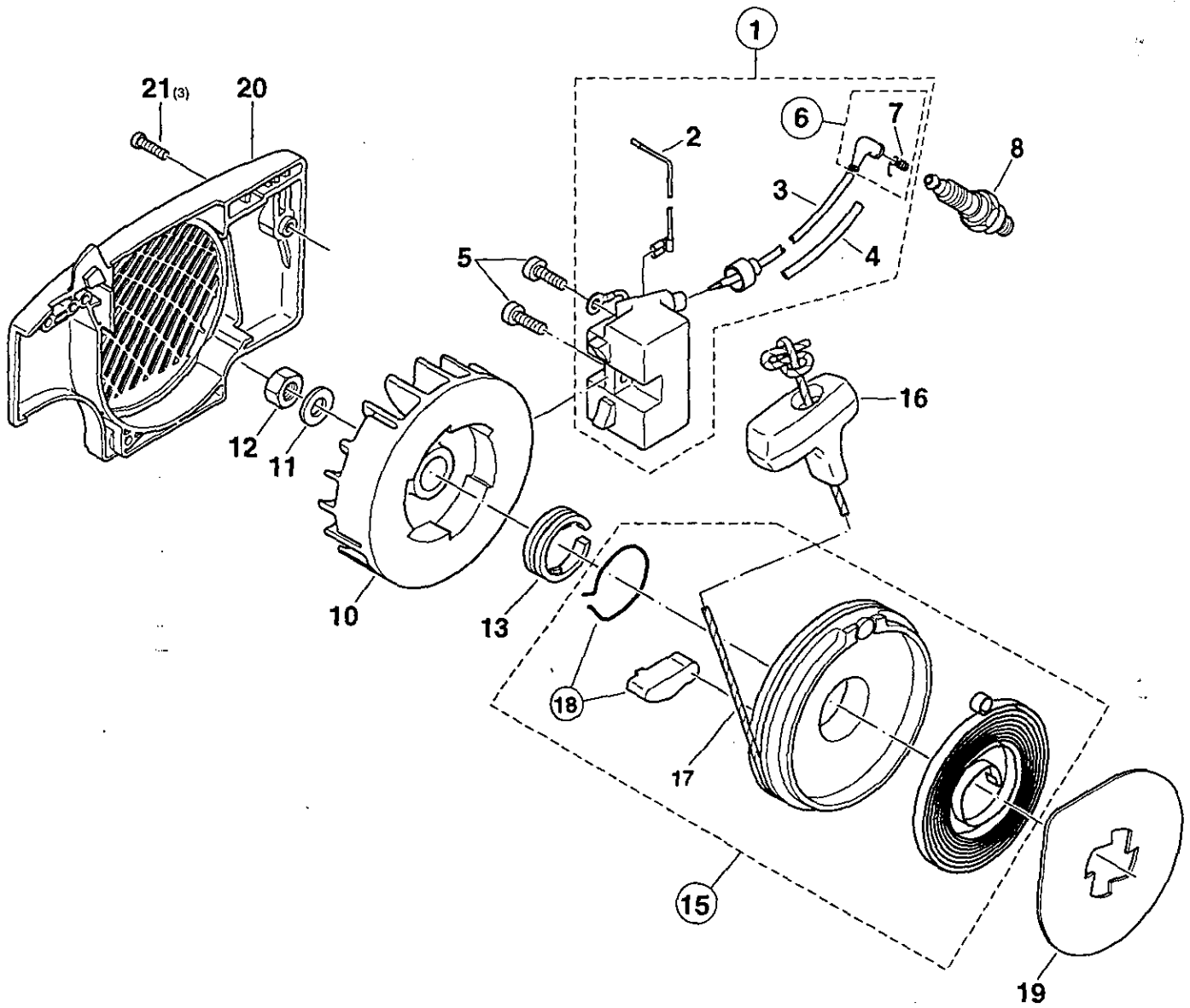

										<b>3</b>	Zündelektronik, Anwerfvorrichtung Ignition electronics, starter Allumage électronique, dispositif de démarrage Bobina encendido, dispositivo de arranque			<b>DOLMAR</b> 
Pos.	Anz. Qty. Qté. Cdad.							Teil-Nr. Part No. No. de pieza	Hinweise Notes Renseig. Nota	Benennung	Description	Désignation	Denominación	
	PS-33/330	PS-340	PS-341	PS-342	PS-344	PS-400	PS-401	PS-410	PS-411					
1	1	1	1	1	1	1	1	1	1	028 142 021	Zündelektronik kpl.	Ignition electronic assy.	Allumage électr. cpl.	Bobina encendido cpl.
2	1	1	1	1	1	1	1	1	1	028 147 000	Kurzschlußkabel	Short-circuit cable	Câble courte-circuit	Cable corto-circuito
3	m*							970 310 200		Zündkabel 300 mm	Ignition cable	Câble de bougie	Cable de encendido	
4	m*							970 502 110		Isolierschlauch 100 mm	Insulating hose	Tuyau isolante	Manga aislante	
5	2	2	2	2	2	2	2	2	2	908 605 145	Schraube $\odot$ M5x14	Screw	Vis	Tomillo
6	1	1	1	1	1	1	1	1	1	957 604 260	Kerzenstecker kpl.	Plug cap cpl.	Fiche de bougie cpl.	Enchufe bujía cpl.
7	1	1	1	1	1	1	1	1	1	965 604 180	Feder	Spring	Ressort	Muelle
8	1	1	1	1	1	1	1	1	1	965 603 018	Zündkerze	Spark plug	Bougie	Bujía
10	1	1	1	1	1	1	1	1	1	021 141 010	Polrad	Flywheel	Roue polaire	Volante encendido
11	1	1	1	1	1	1	1	1	1	928 308 001	Federscheibe	Spring washer	Rondelle ressort	Arandela elástica
12	1	1	1	1	1	1	1	1	1	920 308 024	6kt-Mutter M8x1	Hexagonal nut	Ecrou hexagonal	Tuerca hexagonal
13	1	1	1	1	1	1	1	1	1	021 166 040	Sicherungsring	Snap ring	Circlip	Anillo seguridad
15	1	1	1	1	1	1	1	1	1	021 160 000	Anwerfvorrichtung kpl.	Starter assy.	Dispos. de démarrage cpl.	Dispos. de arranque cpl.
16	1	1	1	1	1	1	1	1	1	965 404 031	Anwerfgriff	Starter grip	Poignée de lancement	Tirador de arranque
17	1	1	1	1	1	1	1	1	1	021 164 010	Anwerfseil 3 x 900 mm	Starter rope	Câble	Cordón de arranque
17	1	1	1	1	1	1	1	1	1	985 000 150	Anwerfseil $\varnothing$ 3 x 100 m	Starter rope	Câble	Cordón de arranque
18	1	1	1	1	1	1	1	1	1	028 166 030	Anwerfklinke/Bremsfeder	Starter ratchet/spring	Cliquet/ressort de frein	Trinquete/resorte
19	1	1	1	1	1	1	1	1	1	900 004 375	Anlaufscheibe	Disc	Disque	Disco de tope
20	1	1	1	1	1	1	1	1	1	028 112 030	Ventilatorgehäuse	Fan housing	Carter de vent.	Cárter de vent.
21	3	3	3	3	3	3	3	3	3	908 005 165	Schraube $\odot$ M5x16	Screw	Vis	Tomillo

PS-33 PS-340 PS-400  
 PS-330 PS-341 PS-401  
 PS-342 PS-410  
 PS-344 PS-411

4

Óilpumpe, Kupplung, Kettenbremse  
 Oil pump, clutch, chain brake  
 Pompe à huile, embrayage, frein de chaîne  
 Bomba de aceite, engrague, freno de cadena

**DOLMAR**

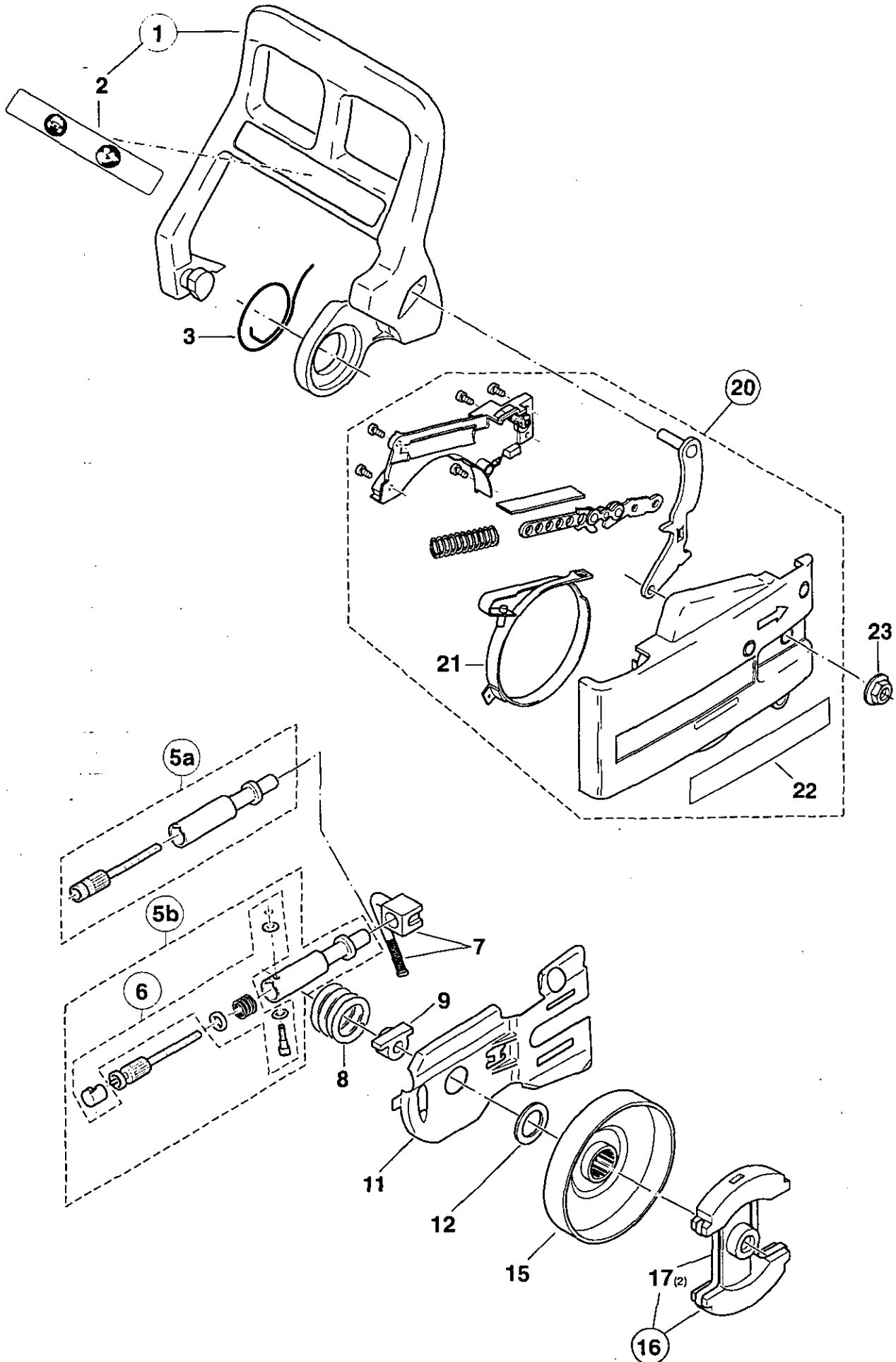

										<b>4</b>	Ölpumpe, Kupplung, Kettenbremse Oil pump, clutch, chain brake Pompe à huile, embrayage, frein de chaîne Bomba de aceite, engrague, freno de cadena	<b>DOLMAR</b> 				
Pos.	Anz. Qty. Cdad.										Teil-Nr. Part No. No. de pièce No. de pieza	Hinweise Notes Renseig. Nota	Benennung	Description	Désignation	Denominación
	PS-33330	PS-340	PS-341	PS-342	PS-344	PS-400	PS-401	PS-410	PS-411							
1	1	1	1	1	1	1	1	1	1	1	028 213 610	=>	Handschutz kpl.	Hand guard cpl.	Protège-main cpl.	Protector de mano cpl.
1	1	1	1	1	1	1	1	1	1	1	028 213 615	<=	Handschutz kpl.	Hand guard cpl.	Protège-main cpl.	Protector de mano cpl.
2	1	1	1	1	1	1	1	1	1	1	980 114 237		Schild	Label	Plaque	Calcomania
3	1	1	1	1	1	1	1	1	1	1	028 213 560		Feder	Spring	Ressort	Muelle
5a	1	1	1	1	1	1	1	1	1	1	021 245 003		Ölpumpe kpl.	Oil pump assy.	Pompe à huile cpl.	Bomba de aceite cpl.
5b										1	028 245 272		Ölpumpe kpl.	Oil pump assy.	Pompe à huile cpl.	Bomba de aceite cpl.
6										1	957 245 270		Satz Ölpumpenteile	Repair kit	Jeu de réparation	Juego de reparar
7	1	1	1	1	1	1	1	1	1	1	965 451 962		Saugleitung für Öl, kpl.	Suction line assy. for oil	Cond. d' aspir. huile cpl.	Cond. de asp. p. aceite cpl.
8	1	1	1	1	1	1	1	1	1	1	021 245 040		Antriebsschnecke	Worm	Vis sans fin	Tornillo sin fin
9	1	1	1	1	1	1	1	1	1	1	021 245 080		Dichtungskappe	Sealing cap	Capot joint	Caperuza junta
11	1	1	1	1	1	1	1	1	1	1	021 111 037		Führungsblech	Guide plate	Tôle guidage	Chapa de guía
12	1	1	1	1	1	1	1	1	1	1	021 224 010		Anlaufscheibe	Shim	Disque de distance	Disco de tope
15	1	1	1	1	1	1	1	1	1	1	028 223 310		Kupplungstrommel 3/8"	Clutch drum	Tambour d'embrague	Tambor
15										1	205 223 100		Kupplungstrommel .325"	Clutch drum	Tambour d'embrague	Tambor
16	1	1	1	1	1	1	1	1	1	1	021 180 011		Kupplung kpl.	Clutch assy.	Embrayage cpl.	Embrague cpl.
17	2	2	2	2	2	2	2	2	2	2	028 184 020		Blattfeder	Flat spring	Ressort à lame	Muelle
20	1	1	1	1	1	1	1	1	1	1	028 213 100		Kettenbremse kpl.	Chain brake cpl.	Frein de chaîne cpl.	Freno de cadena cpl.
21	1	1	1	1	1	1	1	1	1	1	028 213 501		Bremsband	Brake spring	Ressort de frein	Cinta de freno
22	1	1	1	1	1	1	1	1	1	1	980 114 250		Schild DOLMAR	Label	Plaque	Calcomania
23	1	1	1	1	1	1	1	1	1	1	923 208 004		6kt-Mutter M8	Hexagonal nut	Ecrou hexagonal	Tuerca hexagonal

PS-33 PS-340 PS-400  
PS-330 PS-341 PS-401  
PS-342 PS-410  
PS-344 PS-411

5

Schalldämpfer  
Muffler  
Pot d' échappement  
Silencioso

**DOLMAR**

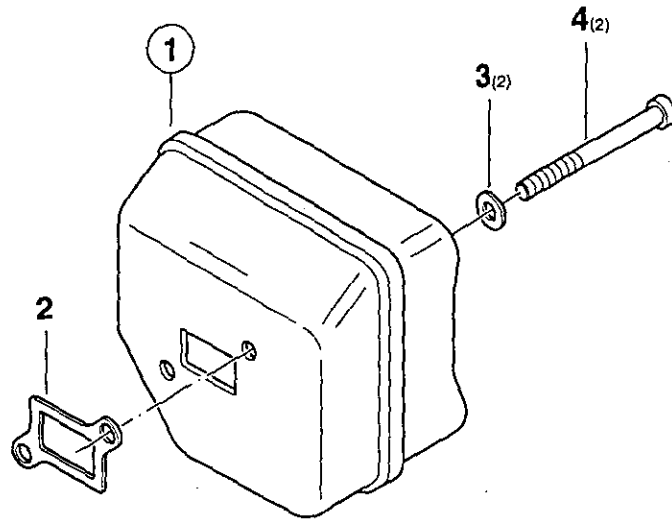

Special parts for USA, CDN, AUS, NZ

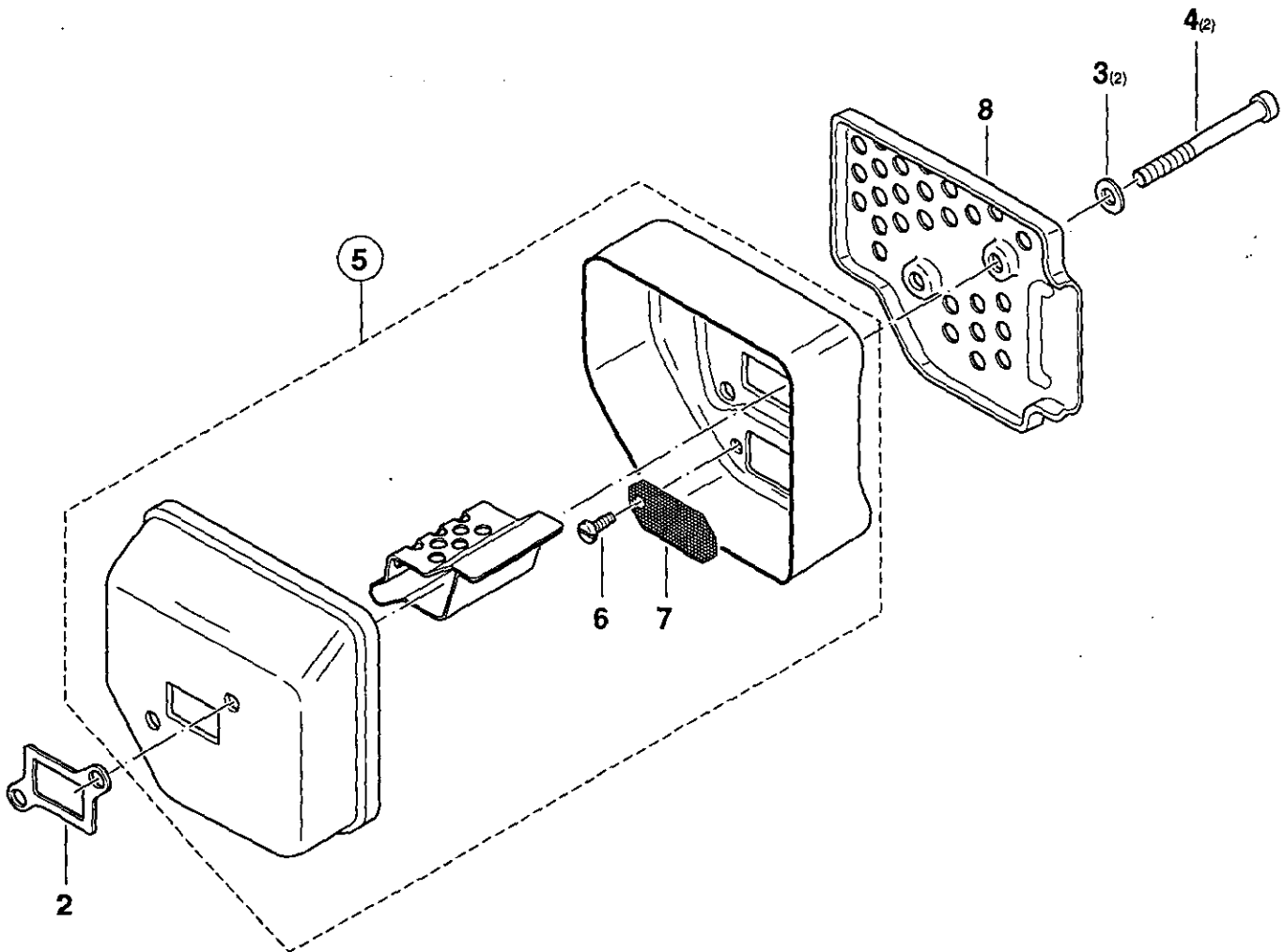



PS-33330 PS-340 PS-341 PS-342 PS-344 PS-400 PS-401 PS-410 PS-411										<b>5</b>		Schalldämpfer Muffler Pot d' échappement Silencioso			<b>DOLMAR</b> 	
Pos.	Anz. Qty. Qté. Cdad.					Teil-Nr. Part No. No. de pièce No. de pieza	Hinweise Notes Renseig. Nota	Benennung	Description	Désignation	Denominación					
1	1	1	1	1	1	11	021 174 300	Schalldämpfer	Muffler	Pot d' échappement	Silenciador					
2	1	1	1	1	1	11	965 524 062	Dichtung	Gasket	Joint	Junta					
3	2	2	2	2	2	22	928 405 000	Spannscheibe	Spring washer	Rondelle à ressort	Arandela					
4	2	2	2	2	2	22	908 205 605	Schraube $\odot$ M5x60	Screw	Vis	Tornillo					
								Spezialteile für USA, CDN, AUS, NZ	Special parts for USA, CDN, AUS, NZ	Pièces spéciales pour USA, CDN, AUS, NZ	Piezas especiales por USA, CDN, AUS, NZ					
5	1	1				11	021 174 320	Schalldämpfer	Muffler	Pot d' échappement	Silenciador					
6	1	1				11	915 135 100	Schraube 3,5 x 9,5	Screw	Vis	Tornillo					
7	1	1				11	021 174 340	Funkenschutzsieb	Spark arrester screen	Tamis	Tamiz					
8	1	1				11	021 174 111	Schutzblech	Heat shield	Protection chaleur	Protector de calor					

PS-33 PS-340 PS-400  
PS-330 PS-341 PS-401  
PS-342 PS-410  
PS-344 PS-411

6

Abdeckhaube, Luftfilter  
Hood, air filter, fan housing  
Capot protecteur, filtre à air  
Cubierta protectora, filtro de aire

**DOLMAR**

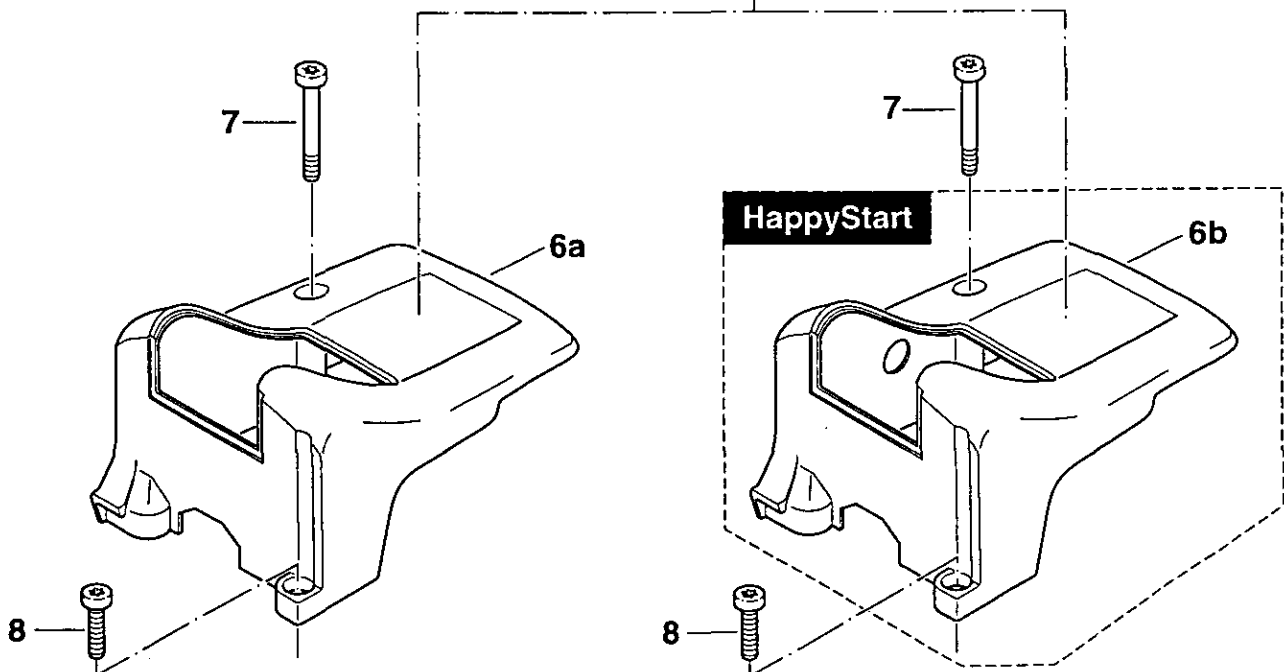
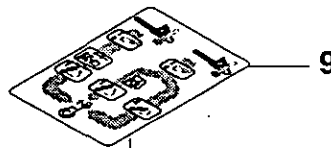
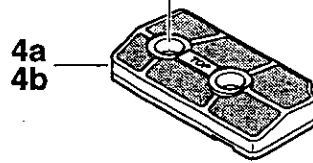
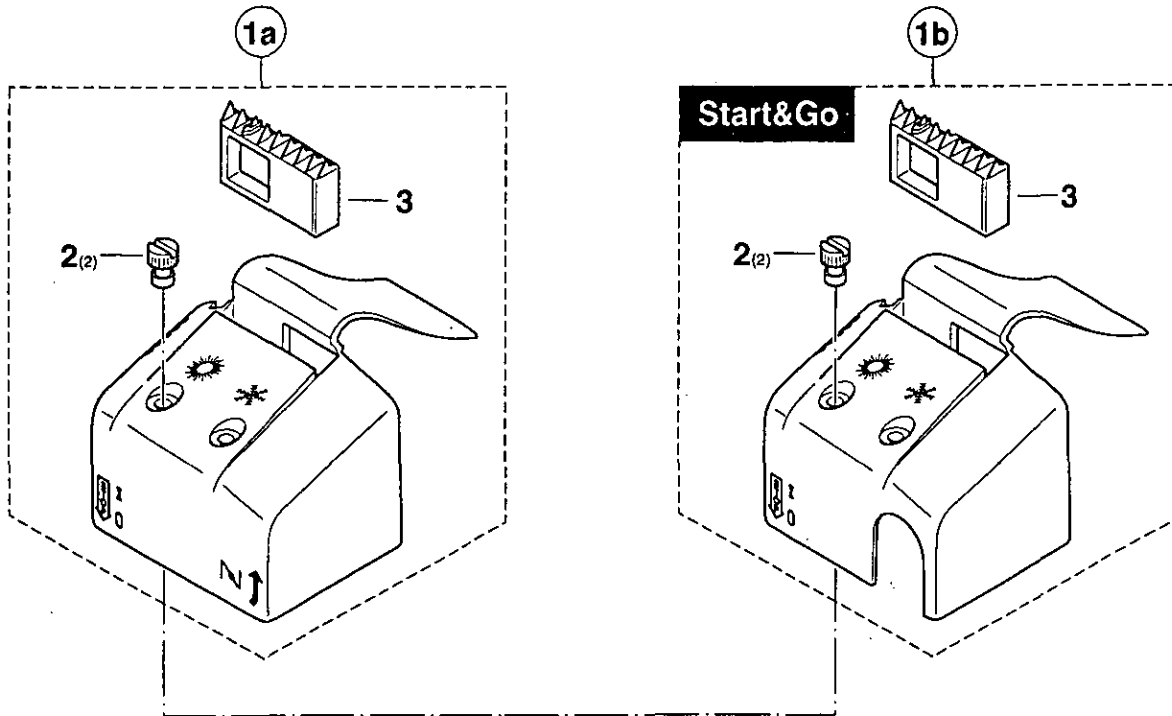

PS-33/330 PS-340 PS-341 PS-342 PS-344 PS-400 PS-401 PS-410 PS-411										6		Abdeckhaube, Luftfilter Hood, air filter, fan housing Capot protecteur, filtre à air Cubierta protectora, filtro de aire				
Pos.	Anz. Qty. Cdad.					Teil-Nr. Part No. No. de pieza	Hinweise Notes Renseig. Nota	Benennung	Description	Désignation	Denominación					
1a	1					028 118 070		Deckel kpl. rot	Cover assy.	Couvercle cpl.	Tapa cpl.					
1a	1	1		1	1	028 118 320		Deckel kpl. schwarz	Cover assy.	Couvercle cpl.	Tapa cpl.					
1b			1	1		028 118 400		Deckel kpl. Start&Go	Cover assy.	Couvercle cpl.	Tapa cpl.					
2	2	2	2	2	2	001 118 062		Mutter MS	Nut	Ecrou	Tuerca					
3	1	1	1	1	1	028 118 180		Einsatz	Insert	Pièce d'insertion	Pieza de cierre					
4a	1	1	1	1	1	028 173 041		Luftfilter (Nylon)	Air filter	Filtre à air	Filtro de aire					
4b	1	1	1	1	1	028 173 141		Luftfilter (Robkoffok)	Air filter	Filtre à air	Filtro de aire					
6a	1					028 118 080		Abdeckhaube rot	Hood	Capot	Cubierta					
6a	1	1	1		1	028 118 310		Abdeckhaube schwarz	Hood	Capot	Cubierta					
6b		1	1	1		028 118 150		Abdeckhaube HappyStart	Hood	Capot	Cubierta					
7	1	1	1	1	1	908 205 605		Schraube ⌀ M5x60	Screw	Vis	Tornillo					
8	1	1	1	1	1	908 005 165		Schraube ⌀ M5x16	Screw	Vis	Tornillo					
9			1			980 114 625		Schild Start&Go	Label	Plaque	Calcomania					
								Spezialteile für USA	Special parts for USA	Pièces spéciales pour USA	Piezas especiales por USA					
1a	1	1		1	1	028 118 050		Deckel kpl. schwarz	Cover assy.	Couvercle cpl.	Tapa cpl.					

PS-33 PS-340 PS-400  
 PS-330 PS-341 PS-401  
 PS-342 PS-410  
 PS-344 PS-411

7

Kraftstofftank, Bùgelgriff  
 Fuel tank, tubular grip  
 Réservoir carburant, poignée tubulaire  
 Depósito de combustible, mango tubular

**DOLMAR**

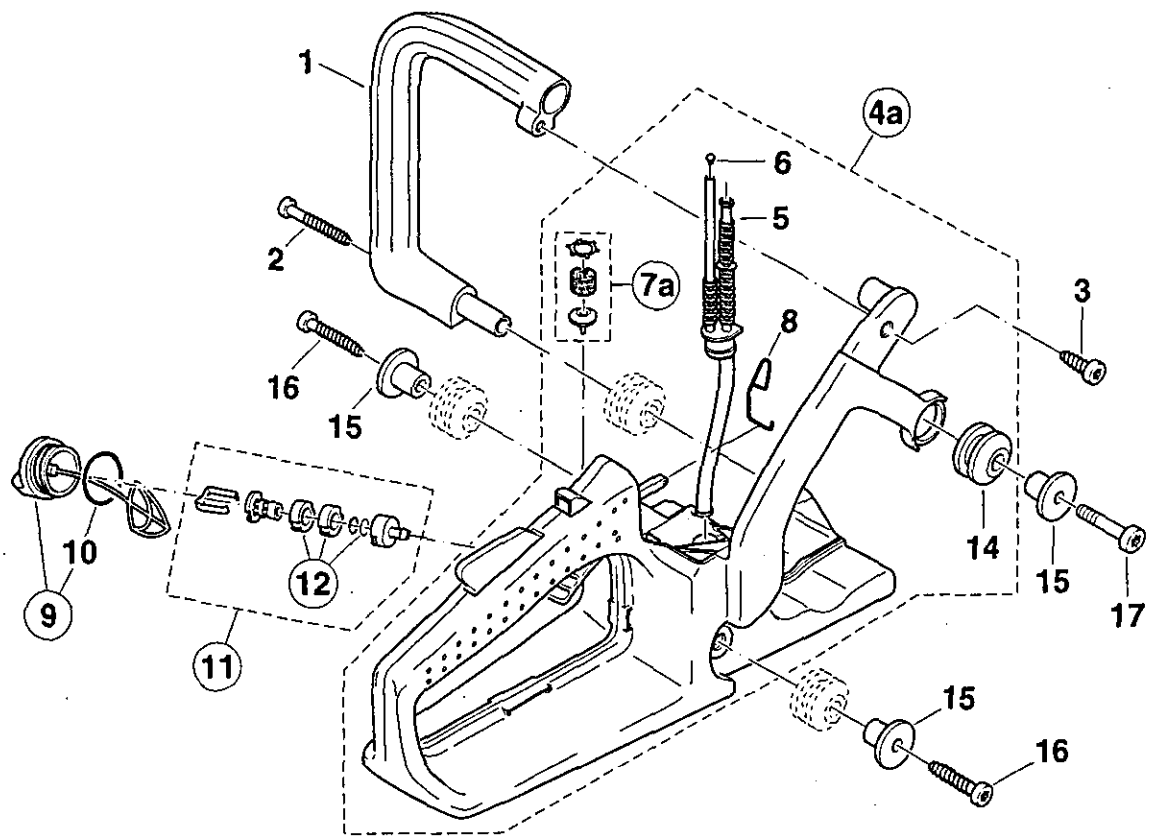

**Start&Go**

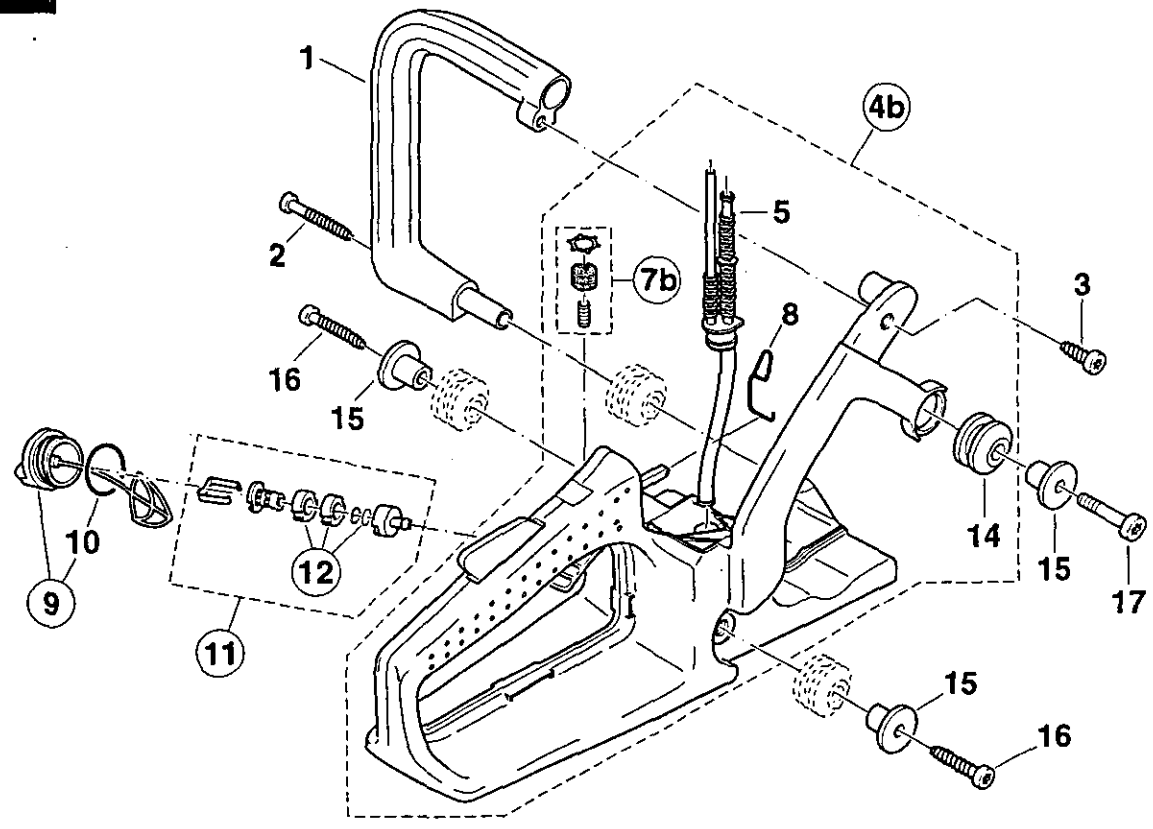

PS-33/330 PS-340 PS-341 PS-342 PS-344 PS-400 PS-401 PS-410 PS-411										7		Kraftstofftank, Bügelgriff Fuel tank, tubular grip Réservoir carburant, poignée tubulaire Dépósito de combustible, mango tubular			DOLMAR 		
Pos.	Anz. Qty. Qté. Cdad.										Teil-Nr. Part No. No. de pièce No. de pieza	Hinweise Notes Renseig. Nota	Benennung	Description	Désignation	Denominación	
1	1	1	1	1	1	1	1	1	1	1	1	028 310 050		Bügelgriff	Tubular handle	Poignée tubulaire	Mango tubular
2	1	1	1	1	1	1	1	1	1	1	1	913 455 454		Schraube $\odot$ 5,5x45	Screw	Vis	Tornillo
3	1	1	1	1	1	1	1	1	1	1	1	913 455 204		Schraube $\odot$ 5,5x20	Screw	Vis	Tornillo
4a	1	1	1								1	028 114 191		Tank kpl.	Tank assy.	Réservoir cpl.	Dépósito cpl.
4b				1	1						1	028 114 200		Tank kpl. Start&Go	Tank assy.	Réservoir cpl.	Dépósito cpl.
5	1	1	1	1	1	1	1	1	1	1	1	965 404 660	=>	Kraftstoffleitung	Fuel line	Conduite carburant	Conducto combustible
5	1	1	1	1	1	1	1	1	1	1	1	965 404 661	=<	Kraftstoffleitung	Fuel line	Conduite carburant	Conducto combustible
6	1	1	1								1	937 130 120		Halbrundniet	Rivet	Rivet	Remache
7a	1	1	1								1	957 114 010		Belüftungsventil kpl.	Vent valve assy.	Soupape d' aération cpl.	Válvula ventilación cpl.
7b				1	1						1	957 114 030		Tankbelüftung kpl.	Tank vent assy.	Soupape d' aération cpl.	Válvula ventilación cpl.
8	1	1	1	1	1	1	1	1	1	1	1	028 117 244		Gasgestänge	Throttle linkage	Tringle d' accélérat.	Varilla acelerador
9	1	1	1	1	1	1	1	1	1	1	1	010 114 050		Tankverschluß kpl.(Kraftst.)	Tank plug assy. (fuel)	Bouchon réserv. cpl. (carb.)	Cierre de depósito cpl.
10	1	1	1	1	1	1	1	1	1	1	1	963 228 030		O-Ring $\varnothing$ 28x3	O-ring	Joint torique	Anillo de guarnición
11	1	1	1	1	1	1	1	1	1	1	1	010 114 010		Saugkopf (Kraftstoff)	Suction head (fuel)	Tête d' aspiration (carb.)	Cabeza de asp. (comb.)
12	1	1	1	1	1	1	1	1	1	1	1	010 114 020		Rep.-Satz, Filter (je 5 Stck.)	Rep. kit, filter (5 of each)	Jeu de réparat., filtre	Juego de reparar, filtro
14	1	1	1	1	1	1	1	1	1	1	1	965 403 490		Schwingungsdämpfer	Rubber buffer	Amortisseur	Amortiguador
15	3	3	3	3	3	3	3	3	3	3	3	021 114 051		Befestigungsbuchse	Fixing bush	Douille de fixation	Casquillo de ajuste
16	2	2	2	2	2	2	2	2	2	2	2	913 455 304		Schraube $\odot$ 5,5x30	Screw	Vis	Tornillo
17	1	1	1	1	1	1	1	1	1	1	1	908 005 305		Schraube $\odot$ M5x30	Screw	Vis	Tornillo

PS-33 PS-340 PS-400  
 PS-330 PS-341 PS-401  
 PS-342 PS-410  
 PS-344 PS-411

8

Boden, Zwischenflansch  
 Bottom, Intermediate flange  
 Fond, bride intermédiaire  
 Fondo, brida intermedia

**DOLMAR**

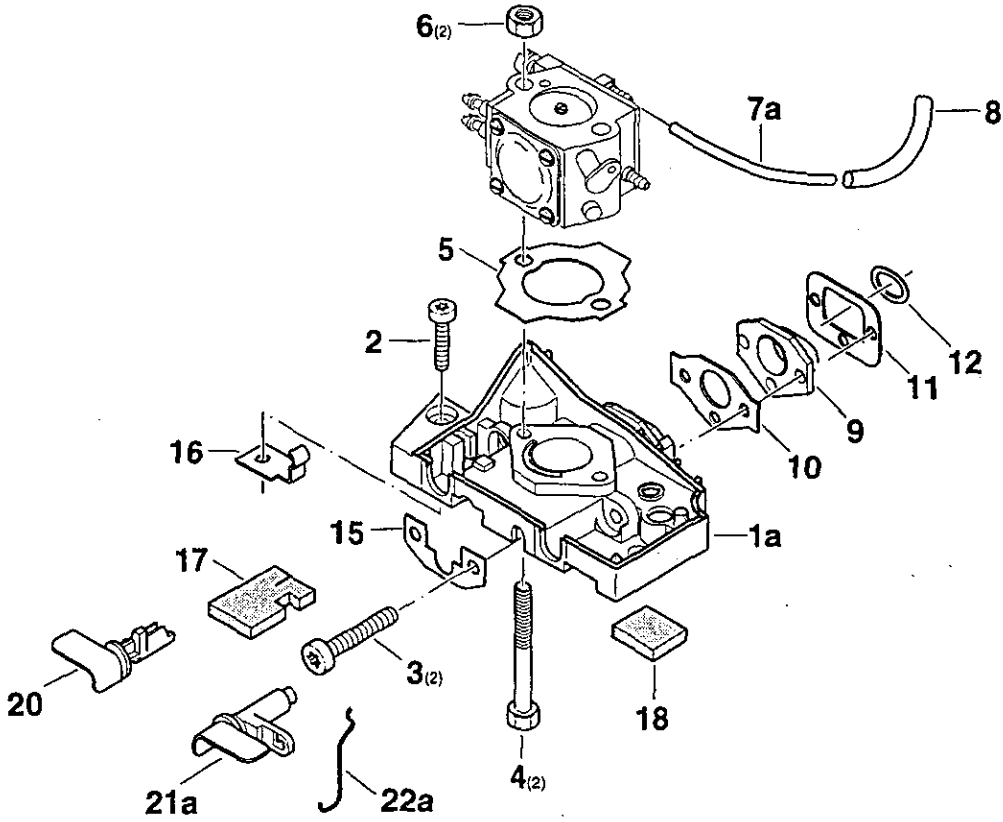

**Start&Go**

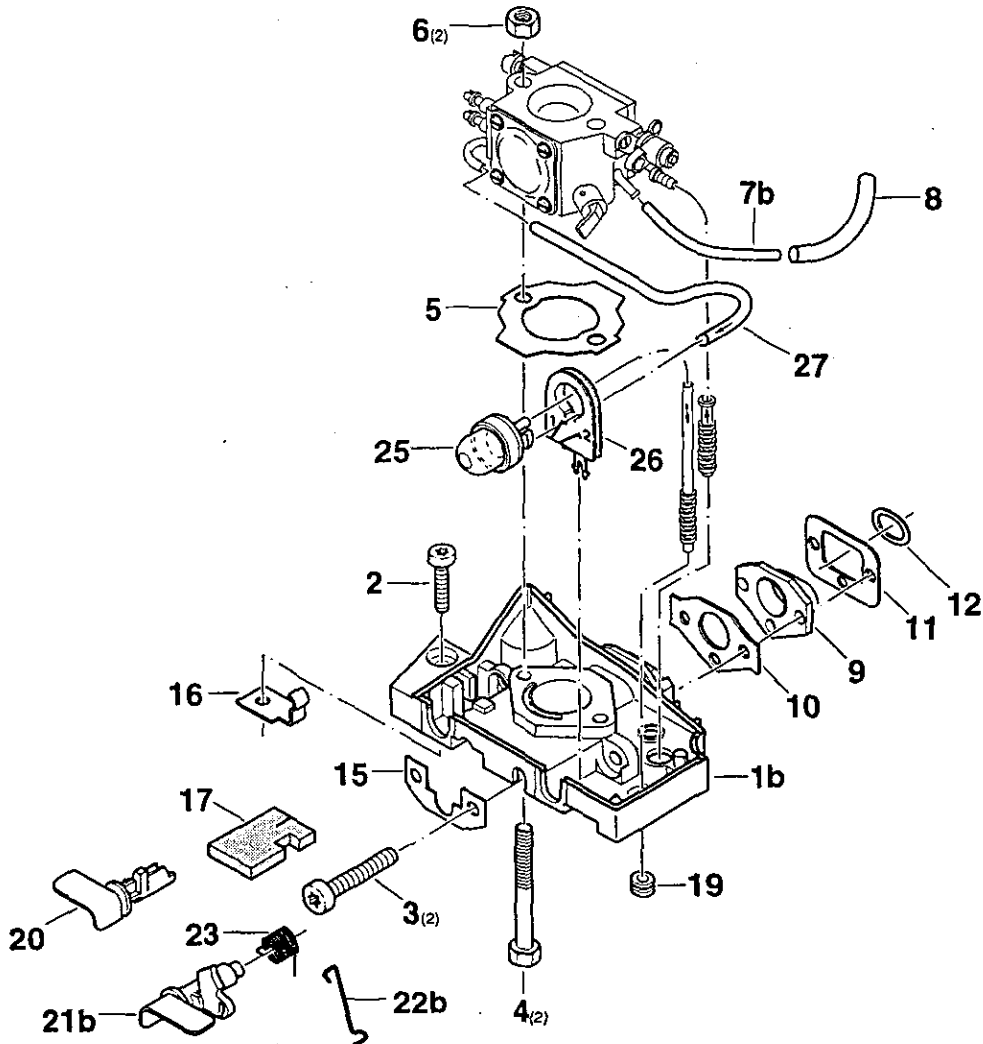

										<b>8</b>		Boden, Zwischenflansch Bottom, Intermediate flange Fond, bride intermédiaire Fondo, brida intermedia			<b>DOLMAR</b> 	
Pos.	Anz. Qty. Qté. Cdad.					Teil-Nr. Part No. No. de pièce No. de pieza	Hinweise Notes Renseig. Nota	Benennung	Description	Désignation	Denominación					
1a	1	1	1		1	1	028 118 271		Boden	Bottom	Fond	Fondo				
1b			1				028 118 380		Boden Start&Go	Bottom	Fond	Fondo				
2	1	1	1	1	1	1	908 005 165		Schraube M5x16	Screw	Vis	Tornillo				
3	2	2	2	2	2	2	908 005 305		Schraube M5x30	Screw	Vis	Tornillo				
4	2	2	2	2	2	2	900 205 554		6kt-Schraube M5x55	Screw	Vis	Tornillo				
5	1	1	1	1	1	1	965 524 120		Dichtung	Gasket	Joint	Junta				
6	2	2	2	2	2	2	920 205 000		6kt-Mutter M5	Hexagonal nut	Ecrou hexagonal	Tuerca hexagonal				
7a	m*						965 452 060		Impulsschlauch 118 mm	Tube	Gaine	Tubo				
7b	m*						965 452 060		Impulsschlauch 87 mm	Tube	Gaine	Tubo				
8	m*						970 502 110		Isolierschlauch 48 mm	Insulating hose	Gaine isolante	Mango aislante				
9	1	1	1	1	1	1	028 131 061		Zwischenflansch	Intermediate flange	Bride intermédiaire	Brida intermedia				
10	1	1	1	1	1	1	965 524 082		Dichtung	Gasket	Joint	Junta				
11	1	1	1	1	1	1	965 524 131		Dichtung	Gasket	Joint	Junta				
12	1	1	1	1	1	1	965 524 092		Dichtung	Gasket	Joint	Junta				
15	1	1	1	1	1	1	028 118 160		Untertegblech	Plate	Tôle	Chapa				
16	1	1	1	1	1	1	028 118 112		Kontaktblech	Contact plate	Tôle de contact	Chapa de contact				
17	1	1	1	1	1	1	965 404 421		Dichtung	Gasket	Joint	Junta				
18	1	1	1		1	1	965 404 430		Dichtung	Gasket	Joint	Junta				
19			1				965 401 011		Gummitülle	Rubber bushing	Gaine caoutchouc	Boquilla de caucho				
20	1	1	1	1	1	1	028 118 121		Stopschalter	Stop switch	Levier d' interrupteur	Palanca de interrupt.				
21a	1	1		1		1	028 150 740		Chokeschalter	Choke lever	Levier de starter	Palanca estrangul. aire				
21b			1				028 117 010		Multifunktionsschalter	Switch	Commutateur	Conmutador				
22a	1	1		1		1	028 150 750		Chokestange	Choke linkage	Tringle de starter	Varillas estrangul. aire				
22b			1				028 155 010		Schaltstange	Switch linkage	Tringle de commande	Vara conmutador				
23			1				028 155 020		Rückstellfeder	Spring	Ressort	Resorte				
25			1				010 155 010		Kraftstoffpumpe "Primer"	Primer	Pompe à carburant	Bomba de combustible				
26			1				028 118 410		Primereinsatz	Primer retaining clip	Pièce d' insertion	Pieza de cierre				
27			1				965 404 530		Kraftstoff-Formschlauch	Fuel line	Gaine	Tubo				





										<b>9</b>		Vergaser Carburetor Carburateur Carburador		WALBRO WT 174 WALBRO WT 466		<b>DOLMAR</b> 	
Pos.	Anz. Qty. Qté. Cdad.					Teil-Nr. Part No. No. de pièce No. de pieza	Hinweise Notes Renseig. Nota	Benennung	Description	Désignation	Denominación						
1a	1	1	1	1	1	028 151 700		Vergaser kpl. WT 174	Carburetor cpl.	Carburateur cpl.	Carburador cpl.						
2	1	1	1	1	1	001 151 140		Pumpendeckel	Pump cover	Couvercle de pompe	Tapa de bomba						
3	1	1	1	1	1	021 151 240		Leerlauf-Anschlagschr. (S)	Adjusting screw	Vis de réglage	Tornillo de tope						
4	1	1	1	1	1	021 151 230		Druckfeder (S)	Pressure spring	Ressort à pression	Resorte de presión						
5	1	1	1	1	1	118 151 190		Schraube	Screw	Vis	Tornillo						
6	1	1	1	1	1	021 151 540		Satz Dichtung/Membrane	Set gasket / diaphragm	Jeu de joint / membrane	Juego junta / membrana						
7	1	1	1	1	1	021 151 120		Membrandeckel	Diaphragm cover	Couvercle de membrane	Tapa de membrana						
8	5	5	5	5	5	118 151 020		Schraube	Screw	Vis	Tornillo						
10	1	1	1	1	1	001 151 320		Drosselklappenwelle	Throttle shaft	Axe clapet d' étrang.	Eje válvula reg.						
11	1	1	1	1	1	001 151 310		Drehfeder	Spring	Ressort	Muelle						
12	1	1	1	1	1	108 151 320		Drosselklappe	Throttle shutter	Clapet d' étranglement	Válvula reg.						
13	2	2	2	2	2	118 151 060		Schraube	Screw	Vis	Tornillo						
14	1	1	1	1	1	108 151 350		Wellensicherung	Shaft clip	Tôle de sécurité	Pieza seguridad árbol						
18	1	1	1	1	1	001 151 255		Chokewelle	Choke shaft	Axe clapet d' air	Eje válvula aire						
19	1	1	1	1	1	001 151 350		Chokeklappe	Choke shutter	Clapet d' air	Válvula aire						
20	1	1	1	1	1	118 151 170		Arretierkugel	Friction ball	Bille de arrêt	Bola						
21	1	1	1	1	1	118 151 160		Arretierfeder	Friction spring	Ressort de arrêt	Muelle						
22	1	1	1	1	1	001 151 515		Vollgas-Stellschraube (H)	Main adjustm. screw	Vis de régl. de plein gaz	Tornillo reg. máx.						
23	1	1	1	1	1	021 151 530		Feder (H)	Spring	Ressort	Muelle						
24	1	1	1	1	1	021 151 470		Leertauf-Stellschraube (L)	Idling adjustm. screw	Vis de régl. de ralenti	Tornillo de tope ral.						
25	1	1	1	1	1	021 151 480		Feder (L)	Spring	Ressort	Muelle						
26	1	1	1	1	1	021 151 180		Sieb	Screen	Filtre	Tamiz						
27	1	1	1	1	1	957 150 040		Satz Steuerteile	Set of control parts	Jeu de pièces de comm.	Juego piezas de mando						
								Spezialteile für USA	Special parts for USA	Pièces spéciales pour USA	Piezas especiales por USA						
1b	1	1	1	1	1	028 151 710		Vergaser kpl. WT 466	Carburetor cpl.	Carburateur cpl.	Carburador cpl.						

PS-33 PS-340 PS-400  
 PS-330 PS-341 PS-401  
 PS-342 PS-410  
 PS-344 PS-411

10

Vergaser  
 Carburetor  
 Carburateur  
 Carburador

TILLOTSON HU-115 A / Start&Go

**DOLMAR**



**Start&Go**

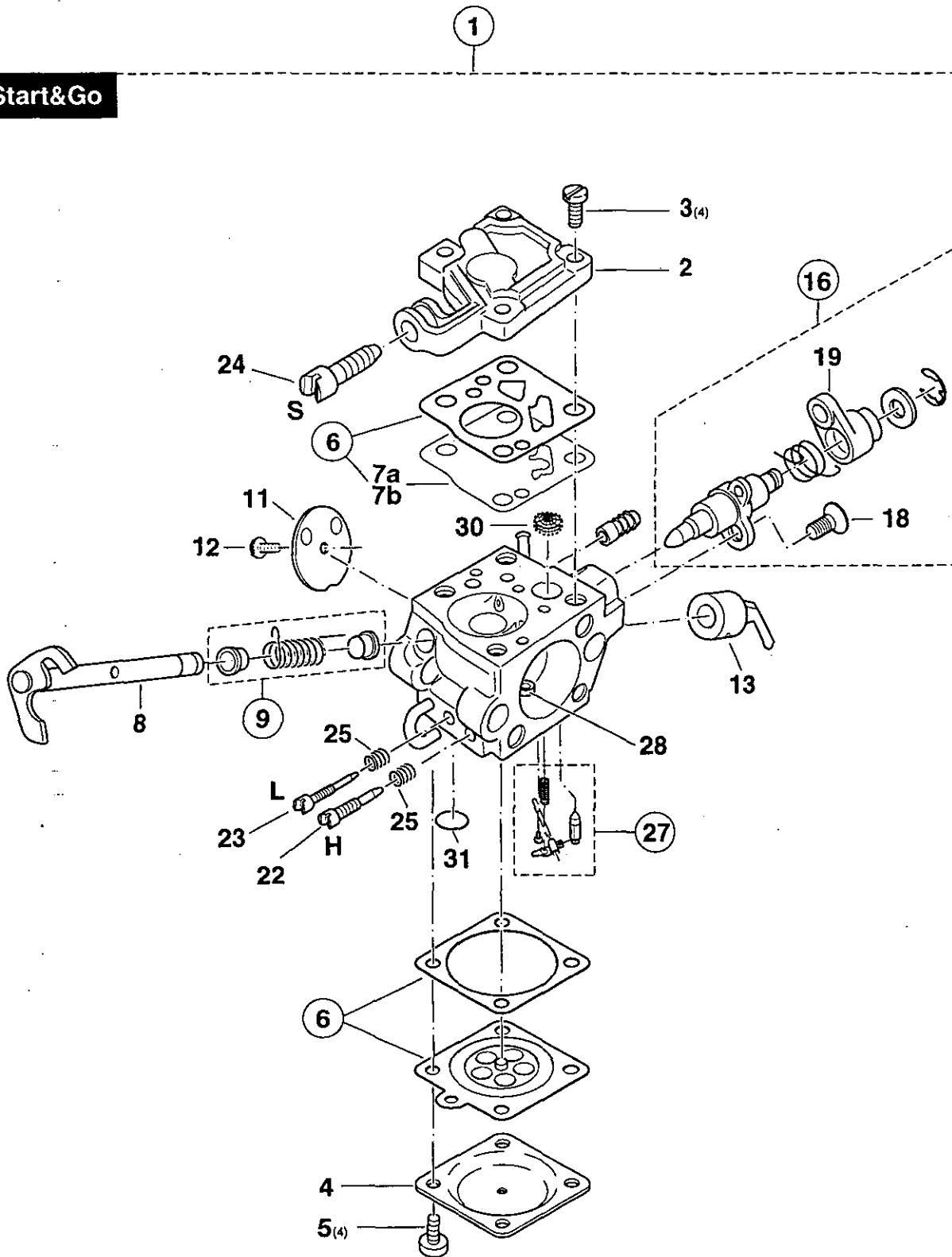

PS-33330 PS-340 PS-341 PS-342 PS-344 PS-400 PS-401 PS-410 PS-411										10		Vergaser Carburetor Carburateur Carburador		TILLOTSON HU-115 A / Start&Go		DOLMAR 	
Pos.	Anz. Qty. Qté. Cdad.		Teil-Nr. Part No. No. de pièce No. de pieza		Hinweise Notes Renseig. Nota		Benennung	Description	Désignation	Denominación							
1		1 1		028 150 010			Vergaser kpl. HU-115 A	Carburetor cpl.	Carburateur cpl.	Carburador cpl.							
2		1 1		020 150 160			Pumpendeckel	Pump cover	Couvercle de pompe	Tapa de bomba							
3		4 4		020 150 170			Zylinderschraube	Fillister head screw	Vis cylindrique	Tornillo cilíndrico							
4		1 1		104 150 120			Membrandeckel	Diaphragm cover	Couvercle de membrane	Tapa de membrana							
5		4 4		001 150 620			Schraube	Screw	Vis	Tornillo							
6		1 1		001 150 700			Membransatz, HU Gummi	Set gasket / diaphragm	Jeu de joint / membrane	Juega junta / membrana							
7a		1 1		100 150 150			Pumpenmembrane, Gummi	Pump diaphr., rubber	Membr. de pompe, caotch.	Membr. d. la bomba, caucho							
7b		= =		001 150 640			Pumpenmembrane, Mylar	Pump diaphr., mylar	Membr. de pompe, mylar	Membr. d. la bomba, mylar							
8		1 1		001 150 410			Drosselklappenwelle	Throttle shaft	Axe clapet d' étranglement	Eje válvula reg.							
9		1 1		957 150 180			Drehfeder kpl.	Spring cpl.	Ressort cpl.	Muelle cpl.							
11		1 1		001 150 321			Drosselklappe	Throttle shutter	Clapet d' étranglement	Válvula reg.							
12		1 1		001 150 650			Schraube	Screw	Vis	Tornillo							
13		1 1		028 155 040			Drosselklappenhebel	Lever	Levier	Palanca							
16		1 1		001 150 690			Injektionsventil kpl.	Injection valve cpl.	Soupape d' injection cpl.	Válvula p. inyecciones cpl.							
18		1 1		113 150 220			Schraube	Screw	Vis	Tornillo							
19		1 1		028 155 030			Hebel	Lever	Levier	Palanca							
22		1 1		020 150 520			Vollgas-Stellschraube (H)	Main adjustm. screw	Vis de régl. d. plein gaz	Tornillo reg. máx.							
23		1 1		020 150 470			Leerlauf-Stellschraube (L)	Idling adjustm. screw	Vis de régl. de ralenti	Tornillo de tope ral.							
24		1 1		020 150 240			Leerlauf-Anschlagschr. (S)	Idle stop screw	Vis de butée de ralenti	Tornillo de toperalenti							
25		2 2		001 150 480			Feder	Spring	Ressort	Muelle							
27		1 1		957 150 170			Satz Steuerteile	Set of control parts	Jeu de pièces de com.	Juego piezas de mando							
28		1 1		020 150 420			Hauptdüse	Main nozzle	Buse	Tobera							
29		1 1		020 150 051			Anschlußnippel	Conecting fitting	Raccord	Niple de conexión							
30		1 1		020 150 180			Sieb	Screen	Filtre	Tamiz							
31		1 1		100 150 040			Verschlussscheibe	Cover disc	Disque de ferm.	Disco de cierre							

PS-33 PS-340 PS-400  
 PS-330 PS-341 PS-401  
 PS-342 PS-410  
 PS-344 PS-411

11

Sägeschiemen, Sägeketten, Werkzeug  
 Guide bars, saw chains, tools  
 Guide-chaîne et chaînes, outils  
 Rieles guía, cadena sierra, herramientas

**DOLMAR**



Guide bar and saw chain combinations meeting kickback requirements of ANSI B 175.1 for the use in the USA

Models PS-340, PS-341, PS-400, PS-401

GUIDE BAR			SAW CHAIN
length	pitch	part no.	part no.
12" (30 cm)	3/8"	412 030 661	528 092 046
14" (35 cm)	3/8"	412 035 661	528 092 052
16" (40 cm)	3/8"	412 040 661	528 092 056

Models PS-410, PS-411

GUIDE BAR			SAW CHAIN
length	pitch	part no.	part no.
15" (38 cm)	.325"	411 407 600	523 085 064

Part numbers of chain parts are available from

**Makita U.S.A., Inc.**

Houston Office  
 12701 Directors Drive  
 Stafford, TX 77477  
 U.S.A.

Guide bar and saw chain combinations meeting kickback requirements of CSA Z62.3 for the use in CANADA

Models PS-340, PS-341, PS-400, PS-401

GUIDE BAR			SAW CHAIN
length	pitch	part no.	part no.
12" (30 cm)	3/8"	412 030 661	528 092 046
14" (35 cm)	3/8"	412 035 661	528 092 052
16" (40 cm)	3/8"	412 040 661	528 092 056

Models PS-410, PS-411

GUIDE BAR			SAW CHAIN
length	pitch	part no.	part no.
15" (38 cm)	.325"	411 407 600	523 085 064

Part numbers of chain parts are available from

**Makita Canada Inc.**

DOLMAR Division  
 1950 Forbes Street  
 Whitby, Ontario  
 Canada, L1N 7B7

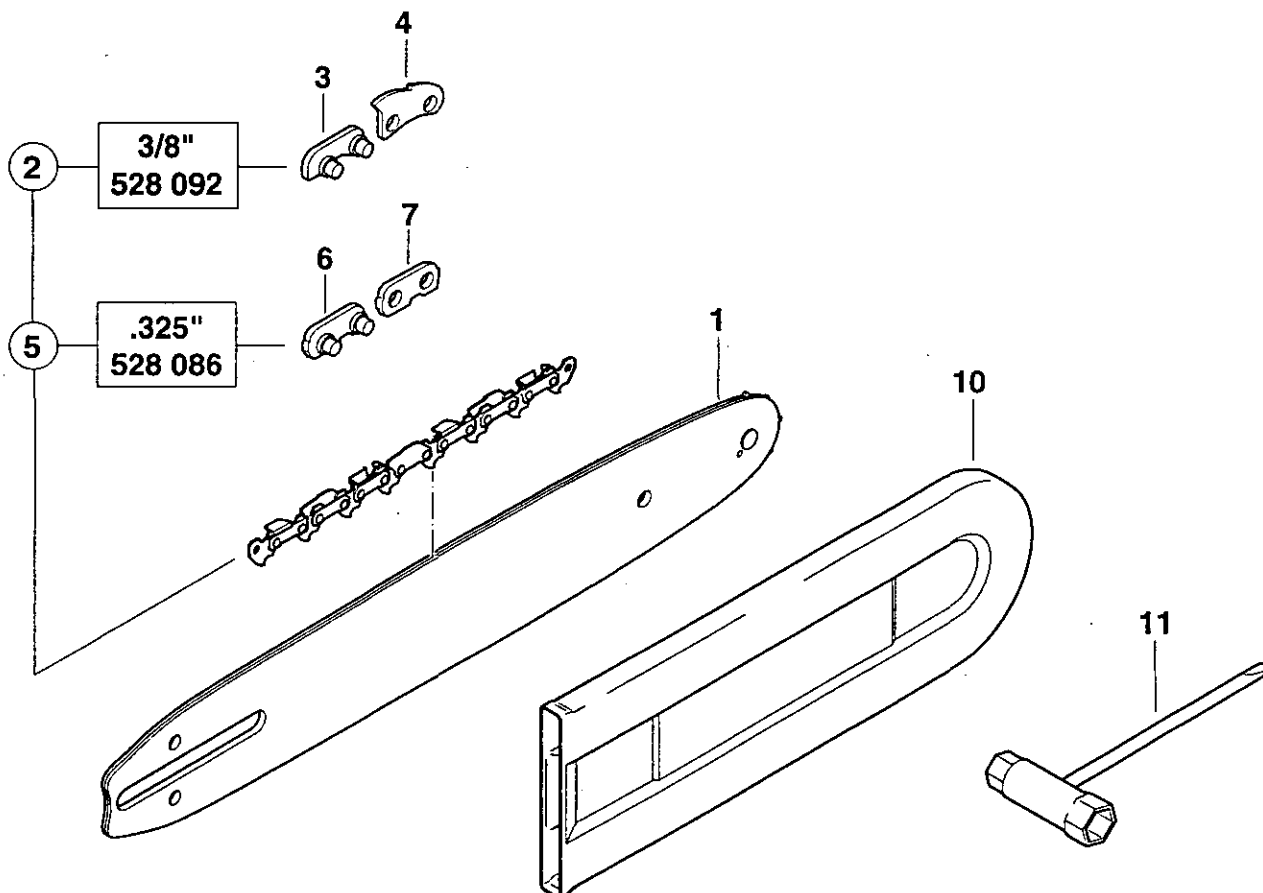

PS-33/330 PS-340 PS-341 PS-342 PS-344 PS-400 PS-401 PS-410 PS-411										<b>11</b>		Sägeschlennen, Sägeketten, Werkzeug Guide bars, saw chains, tools Guide-chaîne et chaînes, outils Rieles guía, cadena sierra, herramientas			<b>DOLMAR</b> 	
Pos.	Anz. Qty. Qté. Cdad.			Teil-Nr. Part No. No. de pièce No. de pieza	Hinweise Notes Renseig. Nota	Benennung	Description	Désignation	Denominación							
						<b>Sternschiene 3/8"</b>	<b>Sprocket nose bar 3/8"</b>	<b>Guide à étoile 3/8"</b>	<b>Barra guía 3/8"</b>							
1	1	1	1	412 030 661		Sternschiene 30 cm	Sprocket nose bar 12"	Guide à étoile	Barra guía							
1	1	1	1	412 035 661		Sternschiene 35 cm	Sprocket nose bar 14"	Guide à étoile	Barra guía							
1	1	1	1	412 040 661		Sternschiene 40 cm	Sprocket nose bar 16"	Guide à étoile	Barra guía							
						<b>Sternschiene .325"</b>	<b>Sprocket nose bar .325"</b>	<b>Guide à étoile .325"</b>	<b>Barra guía .325"</b>							
1				432 033 030		Sternschiene 33 cm	Sprocket nose bar 13"	Guide à étoile	Barra guía							
1				411 407 600		Sternschiene 38 cm	Sprocket nose bar 15"	Guide à étoile	Barra guía							
						<b>Sägekette 3/8"</b>	<b>Saw chain 3/8"</b>	<b>Chaîne 3/8"</b>	<b>Cadena 3/8"</b>							
2	1	1	1	528 092 046		Sägekette 30 cm	Saw chain 12"	Chaîne	Cadena							
2	1	1	1	528 092 052		Sägekette 35 cm	Saw chain 14"	Chaîne	Cadena							
2	1	1	1	528 092 056		Sägekette 40 cm	Saw chain 16"	Chaîne	Cadena							
3	1	1	1	558 092 010		Außenlasche mit Niet	Tie strap with rivets	Eclisse extérieure a. rivets	Tira exter. con remache							
4	1	1	1	558 092 000		Sicherheitslasche	Safety tie strap	Eclisse de sécurité	Tira seguridad							
						<b>Sägekette .325"</b>	<b>Saw chain .325"</b>	<b>Chaîne .325"</b>	<b>Cadena .325"</b>							
5				528 086 056		Sägekette 33 cm	Saw chain 13"	Chaîne	Cadena							
5				528 086 064		Sägekette 38 cm	Saw chain 15"	Chaîne	Cadena							
6				558 083 010		Außenlasche mit Niet	Tie strap with rivets	Eclisse extérieure a. rivets	Tira exter. con remache							
7				558 083 000		Außenlasche	Tie strap	Eclisse extérieure	Tira exter.							
						<b>Kettenschutz 30-40cm</b>	<b>Chain prot. cover 12"-16"</b>	<b>Enveloppe protectrice</b>	<b>Estuche protector</b>							
10	1	1	1	952 100 133		Kombischlüssel SW 13/16	Universal wrench	Clé combinée	Llave de bujía							
11	1	1	1	941 716 131												

PS-33 PS-330	PS-340 PS-341	PS-400 PS-401 PS-410 PS-411	<b>1</b>	Inhaltsverzeichnis Table des matières	Index Indice	<b>DOLMAR</b> 
-----------------	------------------	--------------------------------------	----------	--	-----------------	--

**2**Zylinder, Kurbelgehäuse  
Cylindre, carter- vilebrequinCylinder, crankcase  
Cilindro, carter cigüeñal**3**Zündelektronik, Anwertvorrichtung  
Allumage électronique, dispos. de démarrageIgnition electronics, starter  
Bobina encendido, dispositivo de arranque**4**Ölpumpe, Kupplung, Kettenbremse  
Pompe à huile, embrayage, frein de chaîneOil pump, clutch, chain brake  
Bomba de aceite, embrague, freno de cadena**5**Schalldämpfer  
Pot d'échappementMuffler  
Silencioso**6**Abdeckhaube, Luftfilter  
Capot protecteur, filtre à airHood, air filter  
Cubierta protectora, filtro de aire**7**Kraftstofftank, Bügelgriff  
Réserv. carburant, poignée tubulaireFuel tank, tubular grip  
Depósito de combustible, mango tubular**8**Boden, Zwischenflansch  
Fond, bride intermédiaireBottom, intermediate flange  
Fondo, brida intermedia**9**Vergaser WALBRO  
Carburateur WALBROCarburetor WALBRO  
Carburador WALBRO**10**Vergaser TILLOTSON / Start&Go  
Carburateur TILLOTSON / Start&GoCarburetor TILLOTSON / Start&Go  
Carburador TILLOTSON / Start&Go**11**Sägeschienen, Sägeketten, Werkzeug  
Guide-chaîne et chaînes, outilsGuide bars, saw chains, tools  
Rieles guía, cadenas sierra, herramientas

	Zeichenerklärung	Key to symbols	Légende
→ 1999999 2000000 → 4/95 → SI 5/95 => xxx = { m* ⊙ Corr.	Produktion bis Serien-Nr. Neues Teil ab Serien-Nr. Neues Teil ab Monat / Jahr Siehe Service-Information Monat / Jahr Teil gleichwertig ersetzt Nicht mehr lieferbar Keine Serienausführung, jedoch verwendbar Beinhaltet Positions-Nr. Meterware Innensternschraube Druckfehlerberichtigung	Production to serial number New part from serial number New part from Month / Year See Service-Information Month / Year Modified part No more available No standard execution, may be used Contains item no. Sold by the meter Star socket screw Error correction	Production jusqu'à n° de série Nouvelle pièce à partir du n° de série Nouvelle pièce à partir de Mois / Année Voir Service-Information Mois / Année Pièce modifiée Plus livrable Aucune exécut. en série, cependant utilisable contient n° de numéro Au mètre Vis à étoile intérieure Rectification d'erreurs
	Explicación de símbolos	Verklaring der tekens	Chiarificazione dei simboli
→ 1999999 2000000 → 4/95 → SI 5/95 => xxx = { m* ⊙ Corr.	Producción hasta N° de serie Pieza nueva a partir de N° de serie Pieza nueva a partir de mes / año Véase inform. servicio mes / año Pieza modificada Agotado No es de serie, pero sirve Contiene pos N° Por metro Tornillo estrella interior Fe de erratas	In productie tot serie-Nr. Nieuw onderdeel vanaf serie-Nr. Nieuw onderdeel vanaf maand / jaar Zie service-informatie maand / jaar Vervangen door gelijkwaardig onderdeel Niet meer leverbaar Geen serieuitvoering, maar wel bruikbaar Omvat Positie-Nr. Metergoed Binnen-ster schroef Drukfoutcorrectie	Produzione fino al n. di serie Nuovo pezzo a partire dal n. di serie Nuovo pezzo a partire dal mese / anno Vedere il servizio inform. del mese / anno Pezzo sostituito con un pezzo equivalente Non più disponibile Non è un modello di serie, ma ugualm. utilizza. Comprende la posizione n. Articoli a metro Vite con intaglio a stella Rettifica di errori di stampa
	Tegnforklaring	Teckenförklaring	Merkklen selvitys
→ 1999999 2000000 → 4/95 → SI 5/95 => xxx = { m* ⊙ Corr.	Produktion indtil løbenr. Ny del fra og med løbenr. Ny del fra og med måned / år Se Service-Information måned / år Afløst med tilsvarende del Kan ikke leveres mere Ikke standardudgave, men kan anvendes Inkluderer position nr. Metervare Skruer med indiv. stjerner Rettelser af trykfejl	Produktion t o m serienr Ny detalj fr o m serienr Ny detalj fr o m måned / år Se serviceinformation måned / år Ersatt med motsvarande detalj Kan ej mere leveres Ej serieutförande, men användbar Innehåller positionsnr Metervara Skruv med stjärnspår Korrigerig av tryckfel	Tuotanto sarjanumeroon ... asti Uusi osa alkaen sarjanumerosta Uusi osa alkaen kuukausi / vuosi Katso huolto-ohje kuukausi / vuosi Osa vaihdettu vastaavaan Ei enää toimitettavissa Ei sarjavalmistusta, voidaan kuitenkin käyttää Positionumero sisältyy Metritavara Tähtikolionuvi Painovirheen oikaisu